

产品说明

Applications

NACF.800J1-S5/V 开环霍尔电流传感器适用于对交流、直流、脉冲电流的隔离精确测量，测量时一次侧与二次侧间完全绝缘。

For the electronic measurement of currents: AC, DC, pulsed ..., with galvanic separation between the primary circuits and the secondary circuits.

产品优点 Advantages	产品应用领域 Applications	参照标准 Standards
体积小 Small size and space savings	变频器 Static converters	EN 50178: 1997 IEC 60950-1:2001

主要电气参数 Main electrical data
(@ $\pm I_{PN}$, $R_L = 10\text{ k}\Omega$, $C_L = 10000\text{PF}$, $T_A = 25^\circ\text{C}$)

额定测量电流 I_{PN}	Primary nominal current	800A
测量范围 I_{PM}	Primary current measuring range	$\pm 2400\text{A}$
电源电压 V_C	Supply voltage	DC $\pm 15(1 \pm 5\%)\text{V}$
电流消耗 I_C	Current consumption	$\leq \pm 25\text{mA}$
额定测量输出 V_{OUT}	Output voltage	$\pm 4\text{V}$
输出内阻 R_{OUT}	Output internal resistance	$102\ \Omega$
负载电阻 R_L	Load resistance	$\geq 10\text{k}\ \Omega$

精度 - 动态参数 Accuracy - Dynamic performance data

基本误差 $\delta_i(I_{PN}, T_A = 25^\circ\text{C})$	Accuracy(excluding offset)	$\leq \pm 1\%$ of I_{PN}
线性度 $\delta_L(0 \dots \pm I_{PN})$	Linearity error	$\leq \pm 1\%$ of I_{PN}
零点输出误差 $\delta_z(T_A = 25^\circ\text{C})$	Electrical offset voltage	$\leq \pm 20\text{mV}$
磁滞失调电压 $V_{OH}(I_P = 0, 1 \times I_{PM}$ 冲击后)	Hysteresis offset voltage @ $I_P = 0$, after an excursion of $1 \times I_{PN}$	$\leq \pm 30\text{mV}$
零点温度漂移 $\delta_{zt}(T_A = -40^\circ\text{C} \sim +85^\circ\text{C})$	Temperature coefficient of δ_{zt}	$\leq \pm 1\text{mV}/^\circ\text{C}$
满量程温度漂移 $\delta_{PST}(T_A = -40^\circ\text{C} \sim +85^\circ\text{C})$	Temperature coefficient of V_{OUT}	$\leq \pm 1\text{mV}/^\circ\text{C}$
满量程温度漂移 $\delta_{PST}(T_A = 85^\circ\text{C} \sim 105^\circ\text{C})$	Temperature coefficient of V_{OUT}	$\leq \pm 1.5\text{mV}/^\circ\text{C}$
响应时间 $T_R(90\% \text{ of } I_{PN} \text{ and } di/dt > 50\text{ A}/\mu\text{S})$	Step response time to 90 % of I_{PN}	$\leq 5\mu\text{S}$
带宽(-3dB)BW	Frequency bandwidth (-3dB)	DC ... 25kHz

一般数据 General data

工作温度 T_a	Ambient operating temperature	-40~+105℃
储存温度 T_s	Ambient storage temperature	-45~+105℃
重量 m	Mass	≤300g

绝缘耐压 Insulation coordination

耐压	Voltage for AC insulation test, 50Hz,1min	5kV
绝缘电阻 R_{IS}	Isolation resistance	≥1000MΩ
爬电距离	Creepage distance	9.9mm
电气间隙	Clearance	9.9mm

NACF.800J1-S5/V 电压传感器外形图 Dimensions NACF.800J1-S5/V Series (in mm)

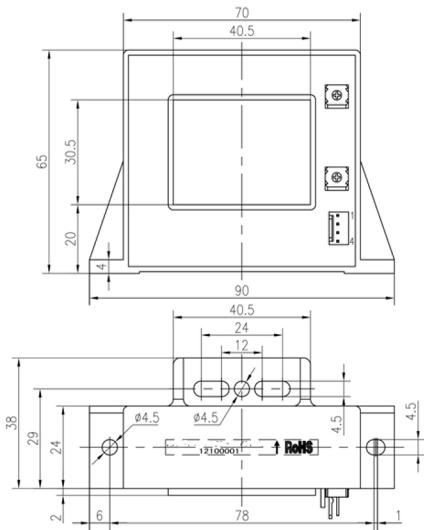

电气连接 Connection

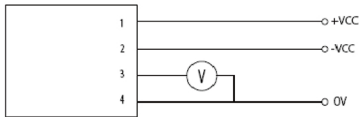

机械特征 Mechanical characteristics

备注 Remark

未注公差

General tolerance

$\pm 1 \text{ mm}$

传感器安装方式一

Transducer fastening

1 hole and 1 notch $\varnothing 5.5\text{mm}$
2 M5 steel screws

传感器安装方式二

Transducer fastening

1 hole and 2 notches $\varnothing 4.5\text{mm}$
3 M4 steel screws

推荐力矩

Recommended fastening torque

$2.5 \text{ N} \cdot \text{m}$

穿心孔

Primary through-hole

$40.5 \times 30.5\text{mm}$

次边电气连接

Connection of secondary

Molex 22-04-1041

- 当测量电流方向与传感器上标示的 方向一致时，传感器输出 V_{OUT} 为正。
- 产品二次侧连接线优选屏蔽线，屏蔽层接近产品端连接线可接机壳，负电源或电源 0V
- 传感器安装螺钉孔的垂直度要求：要求在国家标准 8 级或以上（或 0.06 以下）。
- 传感器接插件要求：接插件必须选用厂家提供的配件，禁止使用其它同型号类似配件。

传感器安装平面度要求：

- 大平面安装平面度国家标准 11 级或以上（或平面起伏小于 0.25mm ）；
- 安装面若有小圆凸台设计时平面度要求达国家标准 12 级或以上（或平面起伏小于 0.5mm ）。